

| REVISIONS |                                   |          |           |
|-----------|-----------------------------------|----------|-----------|
| REV       | DESCRIPTION                       | DATE     | APPROVED  |
| A         | RELEASE TO PROD PER ECO 20-26136  | 01/14/20 | DS        |
| B         | FIXED PINOUT PER ECO 20-26871     | 08/26/20 | DS        |
| C         | TOLERANCES PER ECO 20-27117       | 11/18/20 | K.DUBROWN |
| D         | CRIMP CONTACT PN PER ECO 22-28762 | 04/29/22 | K.DUBROWN |

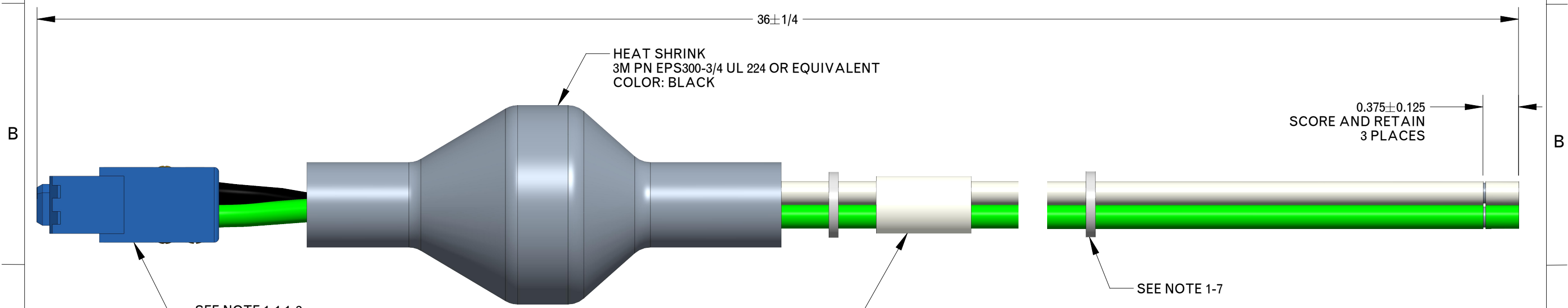

TE CONNECTIVITY RT-1805 OR EQUIVALENT  
 TEXT MUST BE LEGIBLE WITH A  
 0.1" MINIMUM CHARACTER HEIGHT

**SynQor**<sup>®</sup>

LABEL FORMAT:  
 SYNQOR LOGO (AS PROVIDED)  
 CABLE # (MTQ-CBL-ACINPUTP1), SHOULD BE LARGER TEXT  
 DRAWING # (705-1000249)/REV  
 DATE CODE (YYWW)

| PIN IN # | WIRE COLOR | DESCRIPTION |
|----------|------------|-------------|
| 1        | GREEN      | GROUND      |
| 2        | BLACK      | LINE 1      |
| 3        | WHITE      | LINE 2      |

- NOTES:**
- CONNECTOR: POSITRONIC PLB3W3F0050-AA OR EQUIVALENT
  - CRIMP TERMINAL: POSITRONIC FC612N2 QTY 3 OR EQUIVALENT
  - ALL EQUIVALENT CHANGES MUST BE REVIEWED BY SYNQOR AND APPROVED PRIOR TO USE.
  - WIRE: 12 AWG UL AWM STYLE 1569 - 300V 105° C / CSA TYPE TRSR-64, 65/30 STANDING
  - INSTALL 2X AXIAL FERRITE VACUUMSCHMELZE PN T60006-L2016-W403 PER DIAGRAM ON SHEET 2
  - INSTALL HEAT SHRINK 3M PN EPS300-3/4 UL 224 OR EQUIVALENT AND CABLE LABEL TE CONNECTIVITY RT-1805 OR EQUIVALENT PER DIAGRAM ON SHEET 3
  - CABLE TIE: SPC PN# VUVT-05M-M OR EQUIVALENT, MIN TENSILE STRENGTH 18LBS. QTY 5 SPACED 6"
  - ASSEMBLE CABLE PER IPC/WHMA-A-620, CLASS 3
  - ALL PARTS MUST BE UL RECOGNIZED AND RoHS COMPLIANT
  - CABLE MANUFACTURER MUST FOLLOW CONNECTOR MANUFACTURER'S CRIMP GUIDELINES.
  - ALL PARTS/COMPONENTS MUST BE FREE OF DAMAGE, CUTS.
  - A CERTIFICATE OF CONFORMANCE (C OF C) NEEDS TO BE PROVIDED WITH EACH NEW LOT THAT INDICATES THE PARTS HAVE BEEN MANUFACTURED PER THE SPECIFICATIONS SUPPLIED BY SYNQOR.
  - TOLERANCE ON ALL LENGTH DIMENSIONS IS +/- 0.125" UNLESS OTHERWISE SPECIFIED.

|                                                                                                                                                                                                                                                                                                        |                                                               |                          |                                |                 |                                               |
|--------------------------------------------------------------------------------------------------------------------------------------------------------------------------------------------------------------------------------------------------------------------------------------------------------|---------------------------------------------------------------|--------------------------|--------------------------------|-----------------|-----------------------------------------------|
| <b>TOLERANCES:</b><br>UNLESS OTHERWISE SPECIFIED:<br>ALL DIMENSIONS IN INCHES<br>.X +/- 0.025<br>.XX +/- 0.010<br>.XXX +/- 0.005<br>ANGLES +/- 1°                                                                                                                                                      |                                                               |                          |                                |                 | 155 SWANSON ROAD<br>BOXBOROUGH, MA 01719-1316 |
|                                                                                                                                                                                                                                                                                                        | <b>MTQ ACDC POWER INPUT CABLE</b><br><b>MTQ-CBL-ACINPUTP1</b> |                          |                                |                 |                                               |
| SOURCE: PRO/E 705-1000249_D                                                                                                                                                                                                                                                                            |                                                               |                          |                                |                 |                                               |
| THIS DRAWING IS THE PROPERTY OF SYNQOR INC. IT IS NOT TO BE REPRODUCED OR COPIED, IN WHOLE OR IN PART, OR USED FOR FURNISHING INFORMATION TO OTHERS, OR FOR ANY PURPOSE DETRIMENTAL TO THE INTERESTS OF SYNQOR. THE INFORMATION SHOWN HEREIN MAY BE PROTECTED BY PATENTS OWNED OR CONTROLLED BY SYNQOR | SIZE<br><b>B</b>                                              | DATE<br><b>APR-29-22</b> | DWG. NO.<br><b>705-1000249</b> | REV<br><b>D</b> |                                               |
| SCALE: 1.000                                                                                                                                                                                                                                                                                           |                                                               | DRAWN: KJD               | CHECK:                         | SHEET 1 of 3    |                                               |

1

2

3

4

A

A

B

B

C

C

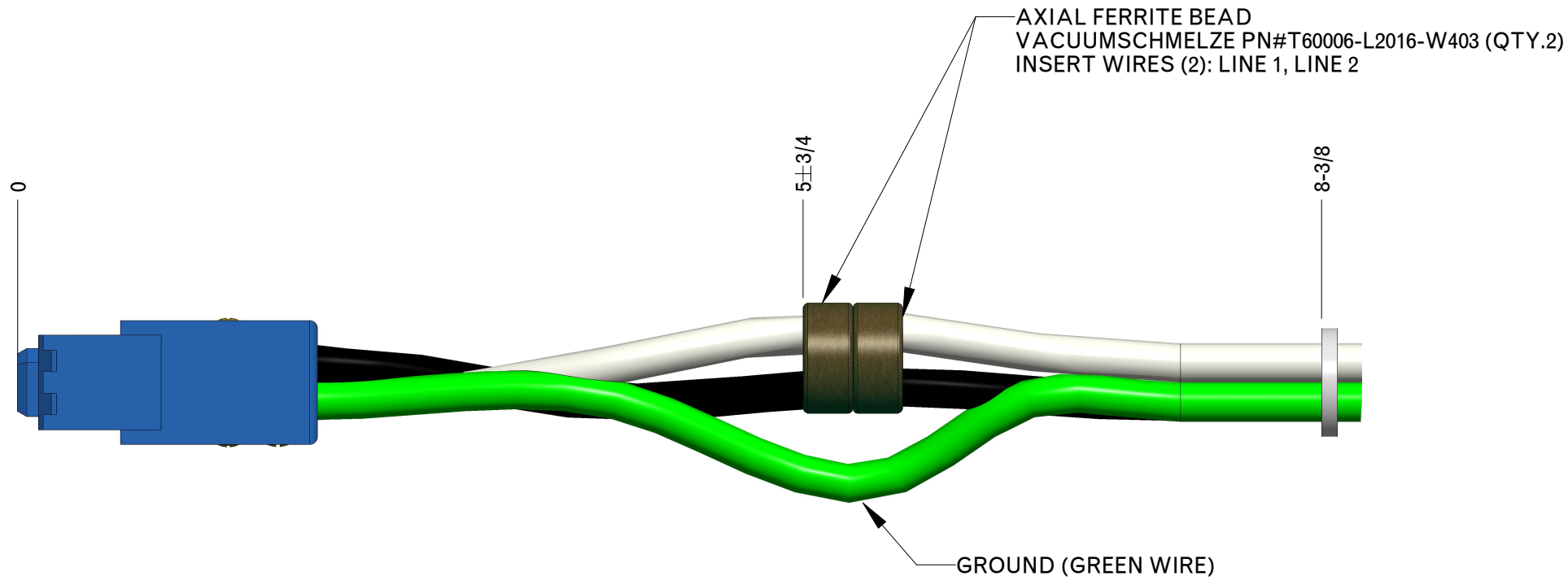

D

D

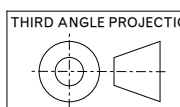

| WIRE COLOR | DESCRIPTION |
|------------|-------------|
| GREEN      | GROUND      |
| WHITE      | LINE 2      |
| BLACK      | LINE 1      |

NOTES:  
 2-1. INSTALL 2X AXIAL FERRITE VACUUMSCHMELZE PN T60006-L2016-W403 PER SHEET 2 DIAGRAM  
 2-2. TOLERANCE ON ALL LENGTH DIMENSIONS IS +/- 0.125" UNLESS OTHERWISE SPECIFIED.

|                                                                                                                                                   |           |                                                                                       |  |                                                                                       |  |                                               |  |
|---------------------------------------------------------------------------------------------------------------------------------------------------|-----------|---------------------------------------------------------------------------------------|--|---------------------------------------------------------------------------------------|--|-----------------------------------------------|--|
| <b>TOLERANCES:</b><br>UNLESS OTHERWISE SPECIFIED:<br>ALL DIMENSIONS IN INCHES<br>.X +/- 0.025<br>.XX +/- 0.010<br>.XXX +/- 0.005<br>ANGLES +/- 1° |           |  |  |  |  | 155 SWANSON ROAD<br>BOXBOROUGH, MA 01719-1316 |  |
|                                                                                                                                                   |           |                                                                                       |  | <b>MTQ ACDC POWER INPUT CABLE</b><br><b>MTQ-CBL-ACINPUTP1</b>                         |  |                                               |  |
| SOURCE: PRO/E 705-1000249_D                                                                                                                       |           |                                                                                       |  |                                                                                       |  |                                               |  |
| SIZE                                                                                                                                              | DATE      | DWG. NO.                                                                              |  | REV                                                                                   |  |                                               |  |
| B                                                                                                                                                 | APR-29-22 | 705-1000249                                                                           |  | D                                                                                     |  |                                               |  |
| SCALE: 1.500                                                                                                                                      |           | DRAWN: KJD                                                                            |  | CHECK:                                                                                |  | SHEET 2 of 3                                  |  |

1

2

3

4

1

2

3

4

A

A

B

B

C

C

D

D

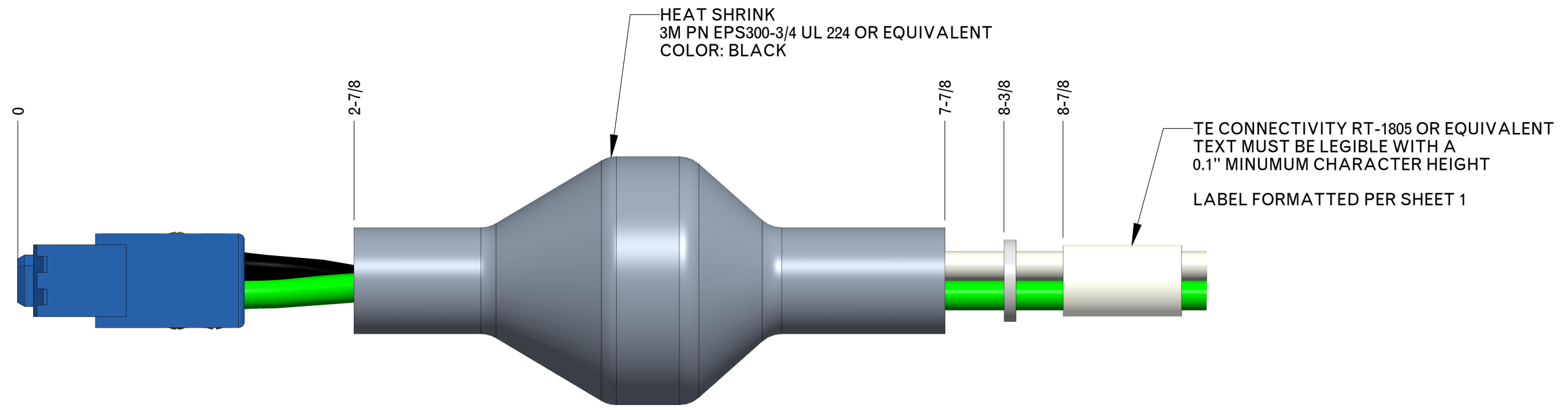

| WIRE COLOR | DESCRIPTION |
|------------|-------------|
| GREEN      | GROUND      |
| WHITE      | LINE 2      |
| BLACK      | LINE 1      |

NOTES:  
 3-1. INSTALL HEAT SHRINK AND LABEL PER SHEET 3  
 3-2. TOLERANCE ON ALL LENGTH DIMENSIONS IS +/- 0.125" UNLESS OTHERWISE SPECIFIED.

|                                                                                                                                                                                                                                                                                                        |                                                               |                          |                                |                 |                                               |  |
|--------------------------------------------------------------------------------------------------------------------------------------------------------------------------------------------------------------------------------------------------------------------------------------------------------|---------------------------------------------------------------|--------------------------|--------------------------------|-----------------|-----------------------------------------------|--|
| <b>TOLERANCES:</b><br>UNLESS OTHERWISE SPECIFIED:<br>ALL DIMENSIONS IN INCHES<br>.X +/- 0.025<br>.XX +/- 0.010<br>.XXX +/- 0.005<br>ANGLES +/- 1°                                                                                                                                                      |                                                               |                          |                                |                 | 155 SWANSON ROAD<br>BOXBOROUGH, MA 01719-1316 |  |
|                                                                                                                                                                                                                                                                                                        | <b>MTQ ACDC POWER INPUT CABLE</b><br><b>MTQ-CBL-ACINPUTP1</b> |                          |                                |                 | <b>MTQ-CBL-ACINPUTP1</b>                      |  |
| SOURCE: PRO/E 705-1000249_D                                                                                                                                                                                                                                                                            |                                                               |                          |                                |                 |                                               |  |
| THIS DRAWING IS THE PROPERTY OF SYNQOR INC. IT IS NOT TO BE REPRODUCED OR COPIED, IN WHOLE OR IN PART, OR USED FOR FURNISHING INFORMATION TO OTHERS, OR FOR ANY PURPOSE DETRIMENTAL TO THE INTERESTS OF SYNQOR. THE INFORMATION SHOWN HEREIN MAY BE PROTECTED BY PATENTS OWNED OR CONTROLLED BY SYNQOR | SIZE<br><b>B</b>                                              | DATE<br><b>APR-29-22</b> | DWG. NO.<br><b>705-1000249</b> | REV<br><b>D</b> |                                               |  |
| SCALE: 1.500                                                                                                                                                                                                                                                                                           |                                                               | DRAWN: KJD               | CHECK:                         | SHEET 3 of 3    |                                               |  |

1

2

3

4